

# Voltage Stability Analysis in the Albanian Power System

Marjela Qemali<sup>1</sup>, Raimonda Bualoti<sup>2</sup>, Marialis Çelo<sup>3</sup>

<sup>1</sup> Department of Electric Power System  
Polytechnic University of Tirana  
Sheshi “Nene Tereza”, No.4, 1000 Tirana, ALBANIA  
Email: m\_qemali {at} yahoo.com

<sup>2</sup> Department of Electric Power Systems  
Polytechnic University of Tirana  
Sheshi “Nene Tereza”, No.4, 1000 Tirana, ALBANIA  
Email: bualoti {at} icc-al.org

<sup>3</sup> Albanian Power Corporation  
Blloku “Vasil Shanto”, no.2, 1010 Tirana, ALBANIA  
Email: celom {at} kesh.al

---

**ABSTRACT**— *With the new social-economical developments and the free moving of the population, the electricity consumption in Albania has changed significantly. The main problem facing by Albania Electric Power System is that the power demand is increasing rapidly whereas the supply growth is constrained by reduced capital availability. Many failures have been occurred in Albanian power systems due to voltage instability, in the past few years. This paper mainly concern steady state voltage stability by capability checking of Albanian power system to maintain the voltage profile in the presence of active/reactive load variations. Voltage stability analysis was performed by utilizing voltage stability tools in NEPLAN software.*

*The paper discusses the results of different methods in comparison of investments impact in the voltage stability. The results have shown that in heavily loaded power system of Albania the voltage stability problems cannot be met with the existing transfer capabilities, even with shunt compensation. New transmission capacities are necessary to improve the voltage stability.*

**Keywords**—Voltage Stability, power system analysis, power system reinforcement, instability

---

## 1. INTRODUCTION

The Albanian power transmission system has a longitude profile from the North to the South part causing in this way a shading profile of the voltage level and many failures due to voltage instability. In recent years, power demand in Albania is increased rapidly while the investments in power system are rather slow. Over 90% of energy in Albanian Power System is produced by hydro power plants. They are mainly located at the Drini River which is in the far north of the country; it represents more than 85% of the total installed generating system capacity. The production capacity varies from 3500 - 4800 up to 7700 GWh respectively in accordance with rainfall rates and hydrologic conditions. That is why 50-90% of the energy demand is fulfilled from local production; the rest is being imported through interconnection lines. The year 2010 was characterized by a maximum power production from the hydro power plants (7702 GWh), fulfilling more than 90% of country electricity demand.

This energy production is concentrated in the north of Albania while the demand is in center and south of the country, this leads on difficult conditions from power flows point of view. Most of major power system breakdown are associated with a sharp change in voltage magnitudes [1], it is importance necessity to analysis the system voltage stability.

The voltage instability problem is analyzed by many different static and dynamic methods. The P–V or Q–V curves are very commonly used as a tool to assess the static voltage stability limit of a power system [2], [3], and [4]. The methods require results by multiple power flow solutions for different load values and/or initial conditions. References [5], [6] used the minimum eigenvalue of the power flow jacobian matrix as a measure of the distance to voltage collapse. The concept of the energy function is used in [7, 8] to establish a voltage stability index. References [9], [10], [11], [12] used a simple equivalent circuit, obtained by applying the concept of Thevenin theorem, to assess the voltage stability limit of a power system. Some of the above methods require global information [7], [8], [13], [14], and are computationally extensive whereas the other methods require only some local information and are computationally less demanding [11], [12], [13], and [14]. A number of countermeasures regarding voltage stability problems have been

adopted by power companies [15], [16]. The most significant ones are reported in [17].

In this paper the voltage stability problems and the countermeasures in different stages of development in Albanian power system has been analyzed. One of the options considered by Albanian power system to overcome voltage problems in the Southern region is to install sufficient shunt compensation device to maintain voltage levels in accordance with the transmission planning criteria. The Q-V analysis was applied to determine suitable locations and sizes of the shunt compensation required to improve the voltage stability. The impact on voltage profile was significant, but the voltage stability limit was not improved. The other option to be considered by Albanian power system is building a new 400kV interconnection power line between Tirana and Podgorica as a need for improvement in generation and transmission capacity as well as an obligation to interconnect Albanian system to the South East Europe Region 400KV system. The impact on Albanian power systems voltage stability limit was significant.

The analysis of the heavily loaded Albanian power system shows that the shunt compensation impact does not solve the voltage stability problems. New transmission line capacities are recommended in the case of a significant increase in consumer load demand.

## 2. THE VOLTAGE STABILITY METHODS

The voltage instability problem is analyzed by many different methods that can be divided mainly into two groups: static and dynamic ones. In this section we will recall a briefly discussed of voltage stability methods which will be used in the analysis of Albanian power system.

*The P-V and Q-V curves methods:* The P-V curves are the most used method of Voltage Security Assessment. The P-V curves are obtained by a parametric study involving a series of AC load flows that monitor changes in one set of load flow variables with respect to another, in a systematic fashion. This procedure allows the determination of transfer limits, which account for voltage and reactive flow effects. They are used to determine the loading margin of a power system. The margin between the voltage collapse point and the current operating point is used as voltage stability criterion [18]. By Q-V curve method is possible to know the maximum reactive power that can be achieved or added to the weakest bus before reaching minimum voltage limit. The reactive power margin is the MVar distance from the (system) operating point to the bottom point of the Q-V curve. The Q-V curve can be used as an index for voltage instability. The point where  $dQ/dV$  is zero is defined as the point of voltage stability limit [19].

*The V-Q sensitivity analysis method:* The V-Q sensitivity of a bus is the slope of its Q-V curve at the given operating point. It can be calculated much more quickly than a full Q-V curve calculation. The V-Q sensitivity analysis calculates the relation between voltage change and reactive power change. The classical reduced Jacobean matrix gives a lot of information about the V-Q sensitivity.

$$\Delta V = J_R^{-1} \Delta Q \quad (1)$$

where:

$J_R$  - the reduced Jacobian matrix,

$\Delta V$  - the voltage change,

$\Delta Q$  - the reactive power change.

The elements of the inversed of the reduced Jacobean matrix represent the V-Q sensitivities. The self-sensitivities coefficients are the diagonal elements  $\partial V_i / \partial Q_i$  and the mutual sensitivities are the non-diagonal ones  $\partial V_k / \partial Q_i$  of the reduced Jacobean matrix.

The signs of the sensitivity coefficients evaluate the system stability, if the sensitivity coefficients are positive the system is considered to be voltage stable. The smaller the sensitivity coefficients the more voltage stable is the system. As stability decreases, the magnitude of the sensitivity coefficients increases, becoming infinite at the limit of stability. In case of negative sensitivity coefficients, the system is considered unstable. The sensitivity coefficients of voltage-controlled buses are zero.

*The Modal analysis method:* The system voltage stability can be evaluated computing the smallest eigenvalue and associated eigenvectors of the reduced Jacobean matrix (1). The eigenvalues are associated with a mode of voltage and reactive power variation. In case of all positive eigenvalues the system is considered to be voltage stable. If one of the eigenvalues is negative, the system is considered to be voltage unstable. A zero eigenvalue means that the system is on the border of voltage instability. The magnitude of minimum eigenvalue provides a measure to know how close the system is to voltage collapse [20]. To identify the voltage weak areas or unstable areas we can calculate the bus participation factor, which gives the relative participation of a bus in a certain mode. It indicates the effectiveness of countermeasures applied at that bus in stabilizing that mode. The branch participation factors indicate which branches consume the most reactive power in response to an incremental change in reactive load. Branches with high

participations are either weak or heavy loaded links. Branch participation factors are useful used for identifying countermeasures that solve voltage stability problems and contingency selection. Generator participation factors indicate which generators supply the highest reactive power in response to an incremental change in system reactive loading. Generator participation factors provide important information regarding proper reactive power distribution reserves among all the machines in order to maintain an adequate voltage stability margin [21].

### 3. ALBANIAN POWER SYSTEM OVERVIEW

One of the problems faced by Albanian Electric Power System today is that the power demand is increasing rapidly whereas the power generation growth is constrained by reduced investments capital availability. The Figure 1.a represents the energy demand trend for the period 1985-2012[1]. The total annual consumption has been increasing, from 2575GWh in 1985 up to 7617GWh in 2012. The Figure 1.b represents the annual peak load trend for the period 1992-2012. The peak value demand in year 2011 was 1450MW that represent 97.1% of Albanian power systems installed capacity of 1531 MW. Reference [1] indicates that the amount of investment in energy companies is accomplished at 11-25% due to lack of financial investments.

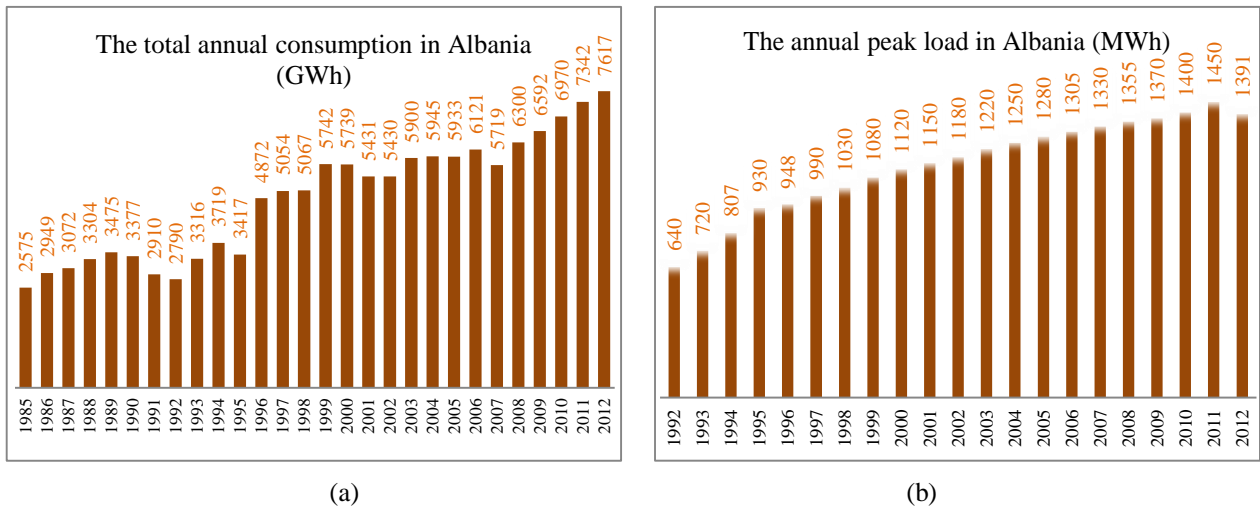

Figure 1: a) The annual consumption 1985-2012 and b) The annual peak load for the period 1992-2012

The Figure 2 shows the loading in MVA of the main transmission lines, 220/400kV in Albanian transmission system, for two different years 1997 and 2010 respectively.

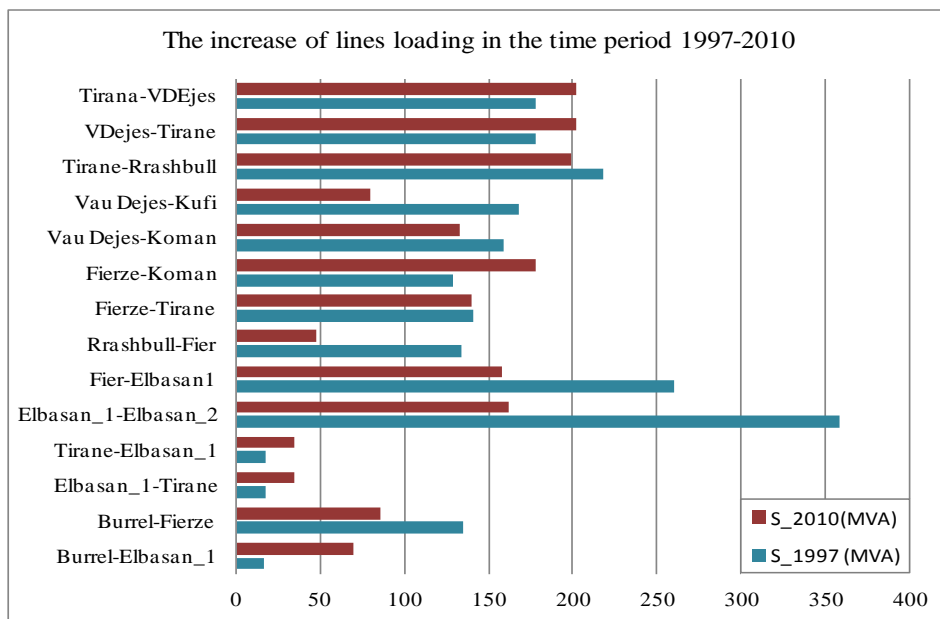
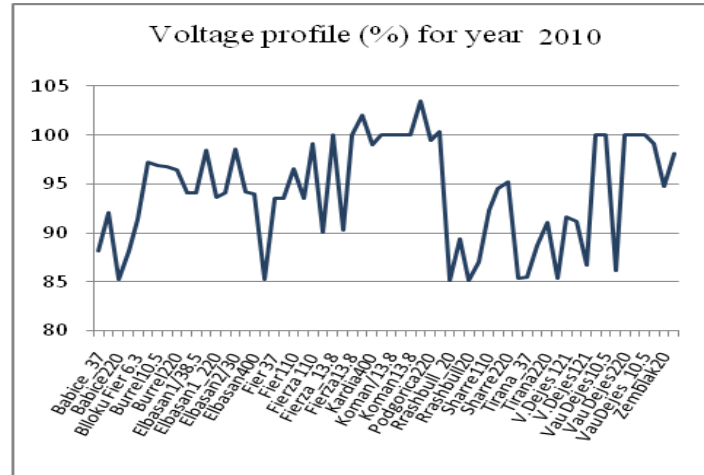

Figure 2: The main 220/400 kV transmission lines loading of Albanian transmission system

We can see from Figure 2 that some transmission lines (exp. Elbasan1-Elbasan2, Elbasan1-Fier, Tirana-Rrashbull) worked at 97% of the maximum capacity.

The transmission system has a longitude profile from the Northern to the Southern part of Albania with main generation at the North part causing in this way high energy losses and a shading profile of the voltage level. The voltage profiles at the main buses for year 2010 are presented in Figure 3.



**Figure 3:** The voltage profiles in Albanian transmission system for year 2010

The overloading of transmission and distributions system and generation capacity availability had lead to blackouts and an emergency under voltage load shedding. This has yields in a need for energy production and improvement use of electricity, needs to new international connections and energy exchanges and new system facilities.

A number of projects are realized in terms of rehabilitation of existing power plants, strengthening the distribution network, while the development in transmission system has been rather slow.

To improve the voltage profiles, the shunt compensation devices are adopted for system reinforcement. The optimal location of shunt compensation devices are defined in [22] based on the weakest buses of the system by P–V curves methods. The lowest P-V curve has been used to determine the optimal location of shunt compensation devices and sensitivity coefficients to determine the measure of compensation. The power utility company has installed a shunt compensation device with capacity ( $Q_c=45.2\text{MVar}$ ) at Fier substation.

The limitations on the generation and transmission capacity as well as the obligation to close through our territory the 400 KV networks of the Balkan region, were crucial to take into account the necessity of construction of new 400kV interconnection line Tirana-Podgorica.

The most of the major power system breakdowns are associated with a sharp change in voltage magnitudes [1]. The system voltage stability analysis has important impact on system voltage stability. In the next section the voltage stability and the impact of system reinforcements in different stages of development in Albanian power system is analyzed.

#### 4. CASE STUDY: ALBANIAN POWER SYSTEM

The NEPLAN software package has been used to study the voltage stability in the Albanian power system. The system includes 65 buses and 20 generators as shown in Figure 4. Voltage stability is calculated using different methods for three following scenarios:

- 1- Base case with maximum load of year 2010 (BC);
- 2- Base case with Shunt compensation device (BC+SH);
- 3- Base case with new transmission line (BC+TL).

The Load Flows have been performed for the three scenarios also; the main buses voltages are presented in Figure 5.

We can see that the use of shunt compensation device has improved by an average 1.3% the system voltage profile and especially up to 3.51% in Fier substation.

The construction of the new 400kV transmission line has significantly affected the system voltage profile by an average 4.5% and up to 8.7% in Fier substation.

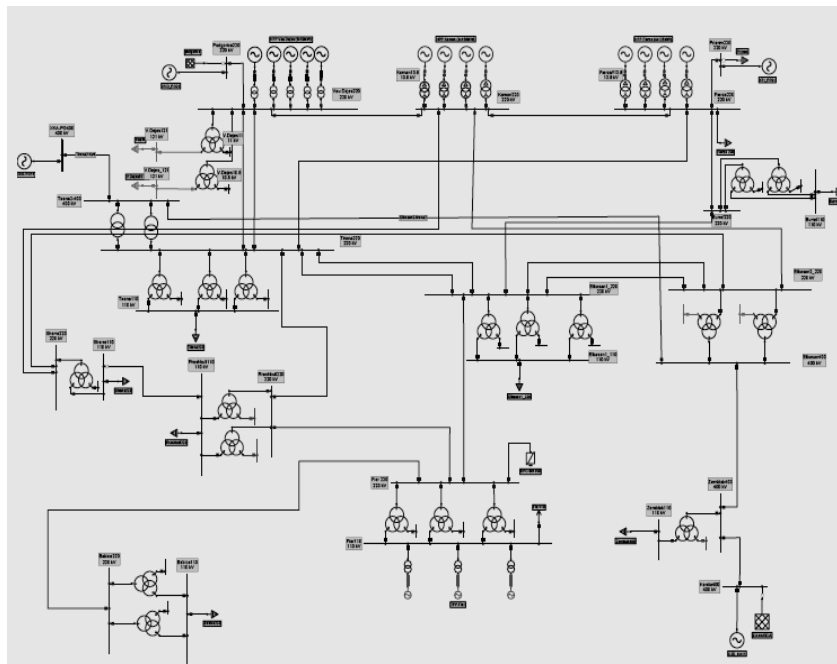

**Figure 4:** The Albanian power system transmission system for year 2010

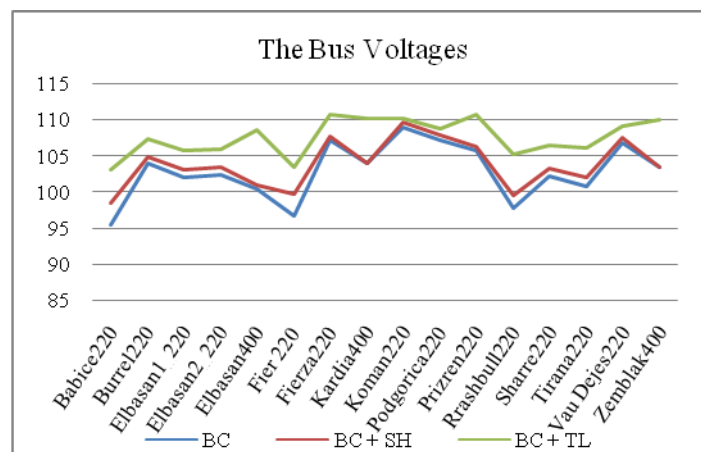

**Figure 5:** The voltage profiles for the three scenarios

In this study we will analyze the static voltage stability by checking the Albanian power system capability to maintain the voltage profile in the presence of active/reactive load variations. Voltage stability analysis is performed by different methods. The results are used to compare the investments impact in the system voltage stability.

#### 4.1 P-V and V-Q curves methods

The P-V and V-Q curve methods identify the weakest bus in the system that yield to, system voltage instability.

##### 4.1.1 P-V curves method

P-V curves are generated by Continue Power Flow methods. The power system load is gradually increased until the nose of the P-V curve is reached. This procedure allows the determination of loading margin of a power system. The bus voltages, generator active power outputs and the branch flows of the systems are monitored. The P-V curves calculated for the three scenarios are shown in the Figure 6. The margin between the voltage collapse point and the current operating point is used as voltage stability criterion. The weakest bus is one that has the lowest active power margin.

For the base case scenario (Figure 6.a), the weakest buses are Babica110, Babica220, Fier220, Rrashbull220 and Sharre110. The loading margin for the weakest bus Babica110 is 108.75%.

For the second case scenario, Base Case with 45.2MVAr shunt compensation device in Fier substation, (Figure 6.b) we observe that the buses with the lowest active power margin are the same and the loading margin of the power system is 110% for the weakest bus Babica110. The margin between the voltage collapse point and the current operating point is improved 1.25%, only in some critical buses like Fier 220, Koman 220, Vau Dejes 220 the loading margin is higher. Shunt compensation device has a limited impact in voltage assessment.

For the third case scenario, Base Case with New 400kV transmission line, (Figure 6.c) we observe that the buses with the lowest active power margin are the same and the loading margin of the power system is 124.75% for the weakest bus Babica110. In the Figure 6.d are represented the P-V curves for the weakest bus Babica110 for all three scenarios.

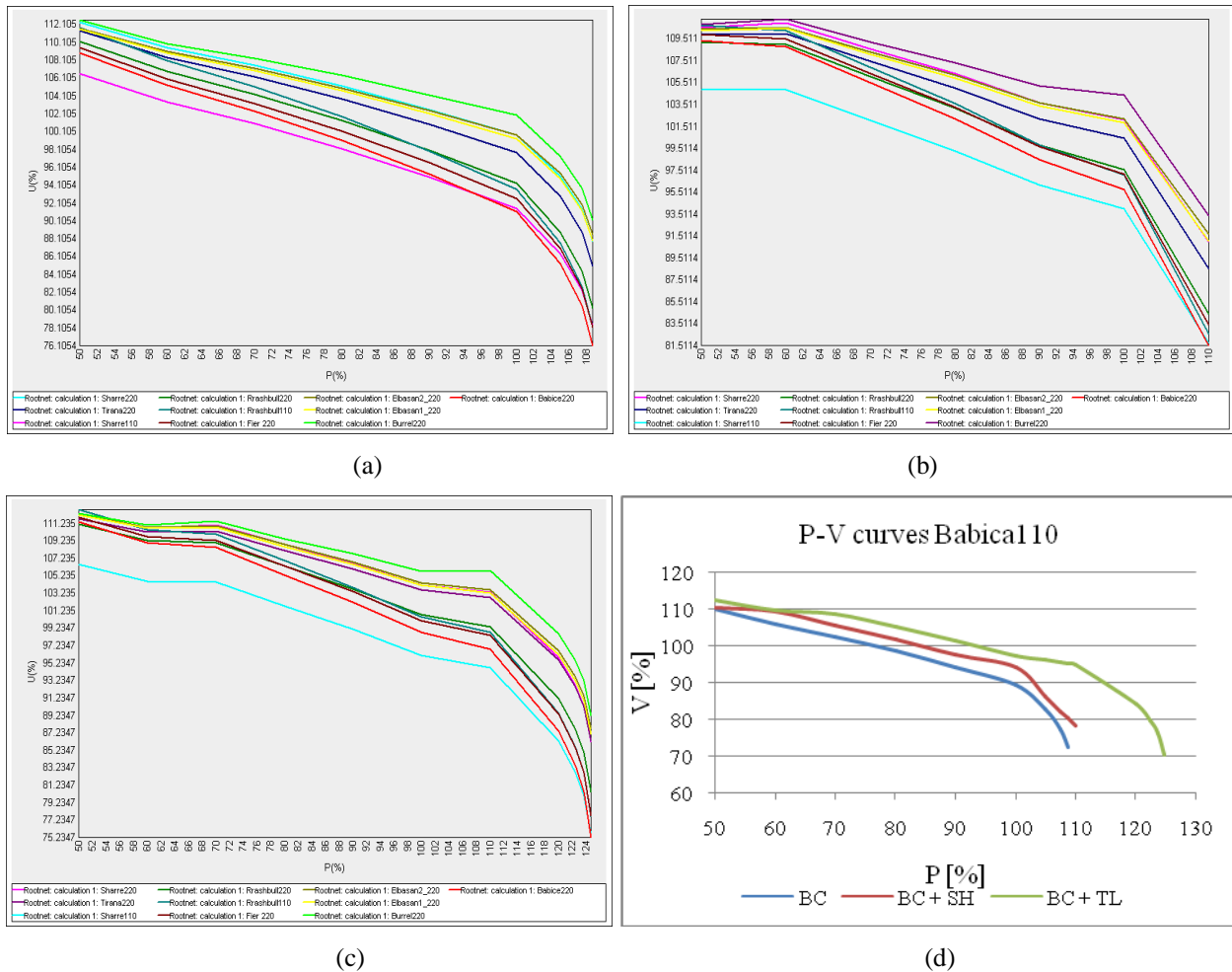

**Figure 6:** The P-V curves for three scenarios:

- a- Base Case for year 2010;
- b- Base Case with shunt compensation device;
- c- Base Case with New transmission line.
- d- The P-V curves for the weakest bus Babica110

At the critical buses Fierza220, Koman220, Vau Dejes220, Koplik220, Kolacem etc. the loading margin are higher. The minimum margin between the voltage collapse point and the current operating point is improved by 16%. The outage of transmission equipment causes the maximum deliverable power to become smaller than the system has had no post-disturbance equilibrium.

#### 4.1.2 The V-Q curves method

The Figure 7 gives an illustration of V-Q curves methods applied to Albanian power system. They show the influence of the system reinforcement in voltage stability. We can identify the weakest bus as one that would fulfill one of the

following conditions: a) the highest voltage collapse point, b) the lowest reactive power margin, c) the greatest reactive power deficiency, and d) the highest percentage change in voltage. Knowing that voltage collapse starts at the weakest bus and then spreads out to other weak buses, we will identify also the other weak buses.

In the base case scenario (Figure 7.a), the weakest bus with the lowest reactive power margin is Babica110 with -64.2 MVar, then other weak buses are Rrashbull110, Sharre110 and Babica220 with respectively -92.8MVar, -95MVar and -95.4MVar resulting in a reactive power deficient system.

For the second scenario, base case with 45.2MVar shunt compensation in Fier substation, (Figure 7.b) we observe that the weak buses are the same as in the first scenario. The lowest reactive power margin is for Babica110 with -76.6 MVar, then other critical buses are Rrashbull110, Sharre110 and Babica220 with respectively -109.4MVar, -107.7MVar and -113.9MVar resulting in a reactive power margin improvement 12.4MVar only and the voltage collapse point has moved from 65% to 60%.

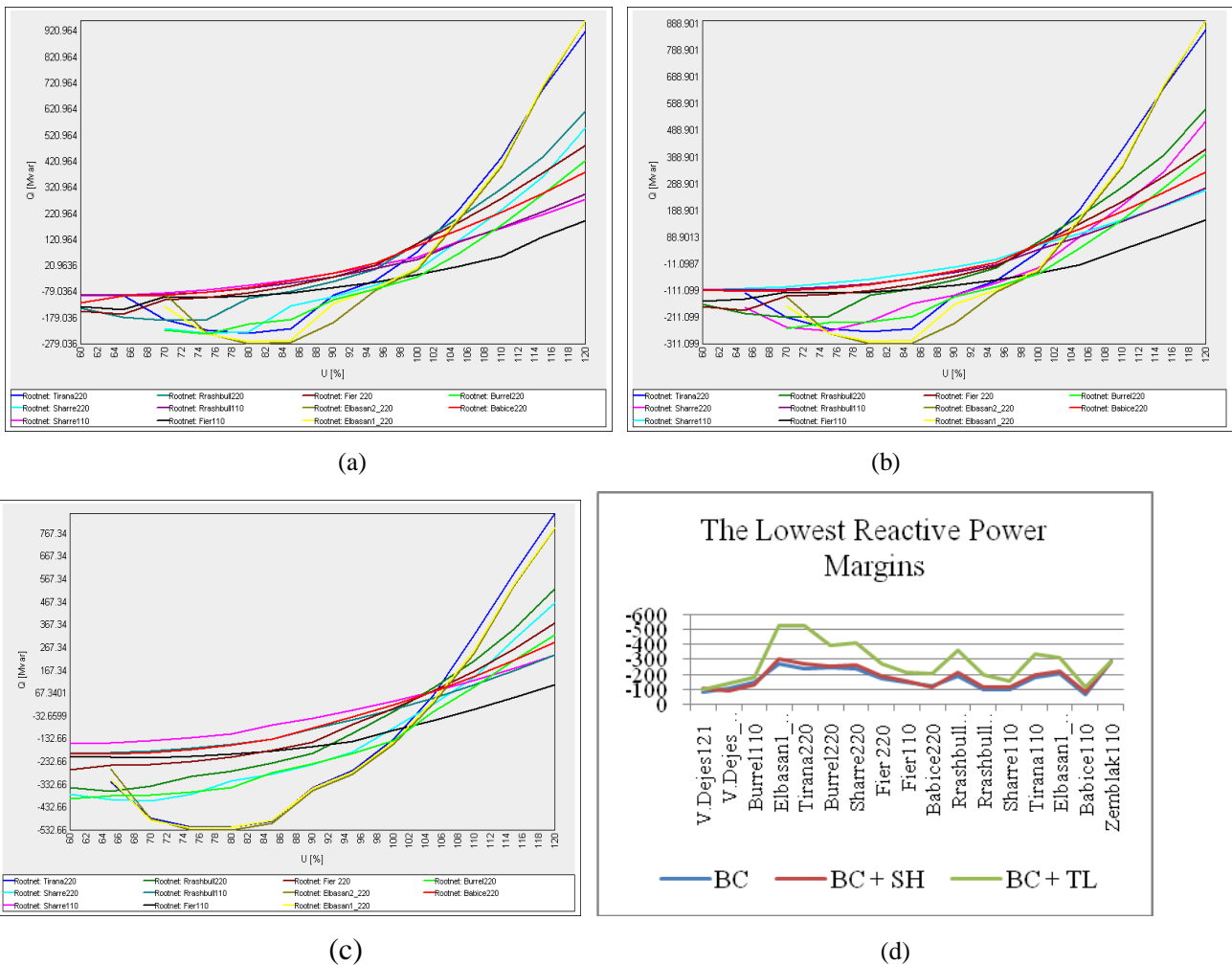

Figure 9: The V-Q curves for three scenarios:

- a- Base Case for year 2010;
- b- Base Case with shunt compensation device;
- c- Base Case with New transmission line.
- d- The lowest reactive power margin for Albanian power system

In the third scenario, base case with new 400kV transmission line, (Figure 7.c) we observe that, the lowest reactive power margin is again for Babica110 with -115.6MVar, then other critical buses are Rrashbull110, Sharre110 and Babica220 with respectively -154.7MVar, -196.7MVar and -200.2MVar.

The lowest reactive power margin is improved with 51.4MVar and the voltage collapse point has moved from 65% to 60%.

In the figure 7.d are represented the lowest reactive power margin for the main buses of Albanian power system for the three scenarios. The use of shunt compensation device as well as the construction of the new 400kV transmission line has improved voltage stability and increased the lowest system reactive power margin.

We can see that use of shunt compensation device has improved by an average -11.8MVAR the lowest system reactive power margin and specially up to -31.3MVAR at Elbasan220 substation. In some other buses like Tirana220, Rashbull220, Sharre220 the lowest system reactive power margin is also improved.

The construction of the new 400kV transmission line has affected significantly the lowest system reactive power margin. It has been improved by -109MVAR as overage and up to -282.6MVAR at Tirana220 substation. In some other critical buses like Elbasan220, Rashbull220, Sharre220 the lowest system reactive power margin is also improved significantly.

Knowing that voltage collapse starts at the weakest bus and then spreads out to other weak buses, the highest percentage change in voltage will be define by using V-Q sensitivity analysis.

#### 4.2 V-Q sensitivity analysis method

The V-Q sensitivity analysis calculates the relation between system voltage change and reactive power change. V-Q sensitivities coefficients identify the nodes with the higher risk of reaching voltage instability at a given operation point. The operation point is stable if sensitivities coefficients values are positive. The smaller sensitivity coefficients value more stable is the system. As stability decreases, the magnitude of the sensitivity coefficients value increases, becoming infinite at the stability limit point.

Table 1 indicates in an increasing order buses with the highest V-Q sensitivities coefficients values for the base case scenario. From the Table 1 we can find that the buses with the highest percentage voltage change and with the higher risk for voltage instability are Babica110, Sharre110, Rrashbull110 and Fier110.

**Table 1:** The V-Q sensitivities coefficients for base case

Bus	V-Q Sensitivity [% / Mvar]
Tirana110	0.070959
Elbasan1_110	0.071511
Zemblak110	0.083658
Fier110	0.114868
Rrashbull110	0.121565
Burre110	0.134636
Sharre110	0.142931
Babice110	0.212312

Table 2 indicates in increasing order buses with the highest values of V-Q sensitivities coefficients for the base case with 45.2MVAR shunt compensation scenario at Fier's substation. .

The use of shunt compensation device has improved voltage stability diminishing the V-Q sensitivities coefficients.

We observe that the buses with the highest V-Q sensitivities coefficients are the same as in the first scenario and the coefficient are slightly smaller. The highest V-Q sensitivities coefficient is 0.008% / MVAR smaller than the first scenario. The shunt compensation device impact on system voltage stability is not significant.

**Table 2:** The V-Q sensitivities coefficients in base case with shunt compensation device

Bus	V-Q Sensitivity [% / Mvar]
Tirana110	0.069434
Elbasan1_110	0.070299
Zemblak110	0.083574
Fier110	0.112112
Rrashbull110	0.118558
Burre110	0.133146
Sharre110	0.140471
Babice110	0.204113

Table 3 indicates in increasing order values of the buses with the highest V-Q sensitivities coefficients sorted for the base case scenario with new 400kV transmission line.



**Table 3:** The V-Q sensitivities coefficients for base case with new transmission line

Bus	V-Q Sensitivity [% / Mvar]
Tirana110	0.05574
Elbasan1_110	0.063612
Zemblak110	0.083269
Fier110	0.099068
Rrashbull110	0.102203
Burrel110	0.126687
Sharre110	0.130694
Babice110	0.183438

From the Table 3 we can see that the sensitivity coefficients are smaller than in the other scenarios, so the system is more stable. The Babica110 continue to be the bus with the higher risk of reaching voltage instability, but the highest V-Q sensitivities coefficients is 0.029% / MVAr smaller or 14% smaller then on base case scenario.

So, the new 400kV transmission line improved also significantly the V-Q sensitivities coefficients.

The V-Q sensitivity analysis indicates that there are more buses at risk of reaching voltage instability for the given operation point.

## 5. RESULTS DISCUSSION

The analysis of results for the base case shows a shading profile of the voltage level and voltage stability problems. This is a consequence of the longitude profile of the Albanian transmission system and lack of generation in the South area.

The analysis with different methods identifies Babica110 the weakest bus of the power system. The loading margin of the weakest bus is 108.75%. The lowest reactive power margin is -64.2MVAr and the highest V-Q sensitivities coefficients 0.21[% / MVAr].

The existing network (system) can cater without any reinforcement or load shedding.

The analysis of results from two scenarios of system reinforcement: a) shunt compensation device at Fier substation and b) new 400kV transmission line Tirana-Podgorica has shown that:

1. The use of shunt compensation device has improved the voltage profile of the system up to 3.51%, while the construction of the new 400kV transmission line has significantly affected the system voltage profile up to 8.7%.
2. From P-V analysis (Table 4), the loading margin for the power system weakest bus, Babica110, increased from 108.75% in case of base scenario with maximum operation for year 2010 to 110% in case of base scenario with shunt compensation device and to 124.75% in base case with new transmission line. The shunt compensation has slightly affected on system voltage stability.

**Table 4:** The loading margin for the weakest bus

P-V analysis for three scenarios	P [%]
Base Case for year 2010	108.75
Base Case with shunt compensation	110
Base Case with New transmission line	124.75

3. From V-Q analysis (Table 5), the lowest reactive power margin for power system weakest bus, Babica110 is improved from -64.2 MVAr for base case to -76.6 MVAr for base case with shunt compensation and to -115.6 MVAr in base case with new transmission line.
4. The voltage collapse point has been improved from 65% to 60%.

**Table 5:** The lowest reactive power margin for the weakest bus

V-Q analysis for three scenarios	U [%]	Q(MVAr)
Base Case for year 2010	108.75	-64.2
Base Case with shunt compensation	110	-76.6
Base Case with New transmission line	124.75	-115.6

5. The impact of shunt compensation device from V-Q sensitivities analysis is not significant. The sensitivity coefficients are smaller for base case with new transmission line; the system is more stable in this case. The risk of reaching voltage instability at a given operation point is smaller and divided to more buses.

## 6. CONCLUSION

The paper subject represents different investments impact by Albanian power system on system voltage stability.

The voltage stability analysis and the results from different calculation methods comparisons is represented.

The simulation results of detailed Albanian power system have shown that the voltage stability problems in heavily loaded of Albania power system cannot be met with the existing transfer capabilities, even with 45.5MVar of shunt compensation device. New transmission line capacities are necessary to improve the voltage stability.

The conclusion and analysis has highlighted the need for reinforcement of the transmission network, as more effective measure to improve the voltage stability in heavily loaded Albanian Power System.

## 7. REFERENCES

- [1] Annual Reports 2005-2012, [www.ere.gov.al](http://www.ere.gov.al)
- [2] C.W. Taylor, Power system voltage stability, McGraw Hill, NY, 1994.
- [3] IEEE/PES Special Publication, Voltage stability assessment, procedures and guides, Final Report, January 2001.
- [4] R.J. Koessler, Voltage instability/collapse – an overview, Proc. IEE Colloquium on Voltage Collapse, London, UK, Digest No. 1997/01, pp. 1/6- 6/6, 1997.
- [5] P.A. Lof, T. Smed, G. Andersson and D.J. Hill, Fast calculation of voltage stability index, IEEE Trans. on PS, Vol. 7, No. 1, pp. 54-60, 1992.
- [6] B. Gao, G.K. Morison and P. Kundur, Voltage stability evaluation using modal analysis, IEEE Trans. on PS, Vol. 7, No. 4, pp. 1529-1542, 1992.
- [7] T.J. Overbye and C.L. DeMarco, Improved techniques for power system voltage stability assessment using energy methods, IEEE Trans. on PS, Vol. 6, No. 4, pp. 1446-1452, 1991.
- [8] T.J. Overbye, Use of energy methods for on-line assessment of power system voltage security, IEEE Trans. on PS, Vol. 8, No. 2, pp. 452-458, 1993.
- [9] A.M. Chebbo, M.R. Irving and M.J.H. Sterling, Voltage collapse proximity indicator: behavior and implications, IEEE Proc. Gener. Transm. Distrib. Vol. 139, No. 3, pp. 241-252, 1992.
- [10] M.H. Haque, A fast method of determining the voltage stability limit of a power system, Electric Power Systems Research, Vol. 32, pp. 35-43, 1995.
- [11] K. Vu, M.M. Begovic, D. Novosel and M.M. Saha, Use of local measurements to estimate voltage stability margin, IEEE Trans. on PS, Vol. 14, No. 3, pp. 1029-1-34, 1999.
- [12] M.H. Haque, On-line monitoring of maximum permissible loading of a power system within voltage stability limit, IEE Proc. – GTD, Vol. 150, No. 1, pp. 107-112, 2003.
- [13] G. Verbic and F. Gubina, Fast voltage-collapse line-protection algorithm based on local phasors, IEEE Proc. – GTD, Vol. 150, No. 4, pp. 482-486, 2003.
- [14] L. Warland and A. T. Holen, Estimation of distance to voltage collapse: Testing and algorithm based on local measurements, Proc. of the 14th PSCC, Sevilla, Spain, 24-28 June 2002.
- [15] Cigre Publication, Criteria and countermeasures for voltage collapse, Cigre Task Force 38-02-12, 1994
- [16] Cigre Publication, Protection against voltage collapse, Cigre Working Group 34-08, 1998.
- [17] C. D.Vournas, Voltage Instability: Phenomena, Countermeasures, and Analysis methods, Proceedings of the IEEE, Vol.88, Issue:2, Feb. 2000, pp.208 – 227.
- [18] Editor/Coordinator: Claudio Canizares, Voltage Stability Assessment: Concepts, Practices and Tools, IEEE/PES Power System Stability Subcommittee Special Publication, August 2002
- [19] P.Kundur, Power System Stability and Control, McGraw-Hill, New York, 1994
- [20] Claudia Reis, F.P. Maciel Barbosa, A Comparison of Voltage Stability Indices, IEEE MELECON 2006, May 16-19, Benalmádena (Málaga), Spain
- [21] [www.neplan.ch](http://www.neplan.ch)
- [22] R.Bualoti, M.Qemali, L.Gjini, N.Hobdari, M.Çelo, A Method For Defining The Location Of Facts Devices – Type SVC, MAKOCIGRE 2009, 6. Conference - Ohrid, Maqedoni. (ID0361) October 4-6, 2009
- [23] A. Yokoyama and T. Kumano, Static voltage stability index using multiple load-flow solutions, EE in Japan, Vol. 111, No. 3, pp. 69-79, 1991.