

System Configuration and Error Performance of Spectral Amplitude Coding Labels in Multi-Rate Optical MPLS Network

Kai-Sheng Chen¹, Chao-Chin Yang^{2,*}, Jen-Fa Huang¹ and Chun-Ting Li¹

¹Institute of Computer and Communication Engineering, National Chen Kung University
No. 1, University Rd., East Dist., Tainan, Republic of China (Taiwan)

²Department of Electro-Optical Engineering, Kun Shan University
No. 195, Kunda Rd., Yongkang Dist., Tainan, Republic of China (Taiwan)

*Corresponding author's email: ccyang [AT] mail.ksu.edu.tw

ABSTRACT— *In this paper, we propose a simple scheme for optical multi-protocol label switching (MPLS) network to support multi-rate data transmissions. Spectral-amplitude coding (SAC) labels of stuffed quadratic congruence (SQC) codes are used for packet switching without multiple access interference (MAI). System performance is analyzed by taking the effects of phase-induced intensity noise (PIIN) and thermal noise into account. We also compare the bit-error rate (BER) of MPLS network with the system where labels of M-sequence codes are employed.*

Keywords— Multi-protocol label switching (MPLS), spectral-amplitude coding (SAC), multiple access interference (MAI), bit-error rate (BER)

1. INTRODUCTION

Since the demand for bandwidth increases in recent years, the optical network is thought as a solution to support massive bandwidth and diverse services. Some methods are proposed to improve network performance. For example, wavelength division multiplexing (WDM) techniques enhance the system capacity of fiber-optic transmission by transmitting data simultaneously on multiple wavelengths in a single fiber. However, repeated optical-electrical-optical conversion at every node limits the application of WDM in optical packet switching (OPS) network. Some all-optical networks are proposed to solve the electronic switching bottleneck and to overcome the slowness of data processing in the electrical domain.

Multi-protocol label switching (MPLS), which switches the packet according to its label, is one of the most efficient protocols for all-optical networks. In the early scheme, labels are deleted and re-encoded after label verification at every node. When label stacking is used, forwarding nodes only execute label recognition to determine the path for packet switching [1]. Because cross-layer processing is no longer required, MPLS network has shorter processing time, compared with other internet protocols.

In order to handle the rapid growing of various applications, multi-rate service is required for the request of transmitting different data types, such as multimedia, voice or video [2], [3]. In this paper, a compact multi-rate scheme of MPLS network is proposed. Stuffed quadratic congruence (SQC) code [4] is used for implementing spectral-amplitude coding (SAC) label. The effects of phase-induced intensity noise (PIIN) and thermal noise are analyzed to derived system performance. Furthermore, the label of M-sequence code is also investigated for bit-error rate (BER) comparison.

2. MULTI-RATE CONFIGURATION FOR MPLS NETWORK

In the proposed MPLS network, stacked labels are assigned to a packet, so multiple access interference (MAI) must be considered. One method to eliminate MAI is using a balanced detector to decode the label code with the fixed-correlation property. Before packet enters the network, a stack of label codes is set by the encoder at edge node based on the label switched path (LSP) [5]. Figure 1 shows the system configuration of packet generation with SAC labels.

Assume that there are two types of packets in the network and SQC codes are used for SAC labels. The first type is a

high-rate packet with bit duration T_1 while the second is low-rate with bit duration T_2 , where $T_1 = 2T_2$. Both packets have the duration T_p . Our scheme of multi-rate transmission is to separate type#1 packet into two. The format of the split packets is the same as type#2. Then, different labels are allocated to all packets, and they are further transmitted to MPLS. The sequential payload bits of type#1 packet are alternated to parallel ones by a serial-to-parallel converter. This block set the format of the split packets the same as type#2 by extending the bit duration.

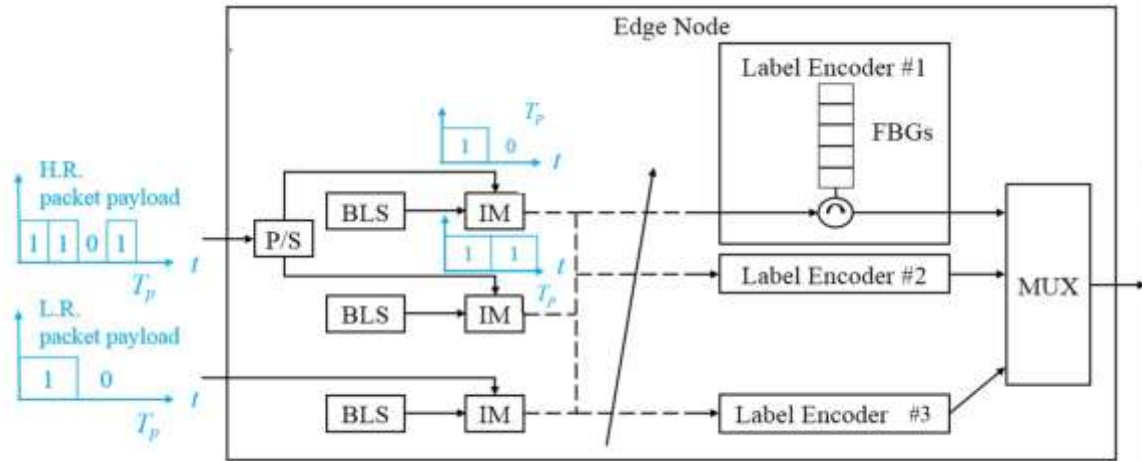

Figure 1: Configuration of Packet Generator with Multi-Rate Transmission at Edge Node. P/S: Parallel-to-Serial; BLS: Broadband Light Source; IM: Intensity Modulator; MUX: Multiplexer

For the proposed label assignment in MPLS network, each path corresponds three distinct labels, $L\#1$, $L\#2$ and $L\#3$. Although a type #1 packet is divided into two, they still have the identical destination or LSP. To transmit these two packets simultaneously without interference, $L\#1$ and $L\#2$ are respectively assigned to them. As for the case of low-rate transmission, there is only one packet with label $L\#3$ sending to the network. The SAC labels are generated by the fiber Bragg grating (FBG)-based decoder in [6].

At forwarding node, labels are verified to determine the next path to switch. If the label of a path matches the one in the label stack, the packet is switched to that path. Figure 2 shows the configuration of forwarding node, where M is the number of paths connected to the node. A packet is split into a few parts when entering the forwarding node. One is sent to fiber delay line (FDL) to wait for the completion of label verification process, and other parts are forwarded to label processors to recognize the labels in the stack. If one of the labels matches, a control signal is generated to turn on the switch and let the packet pass through.

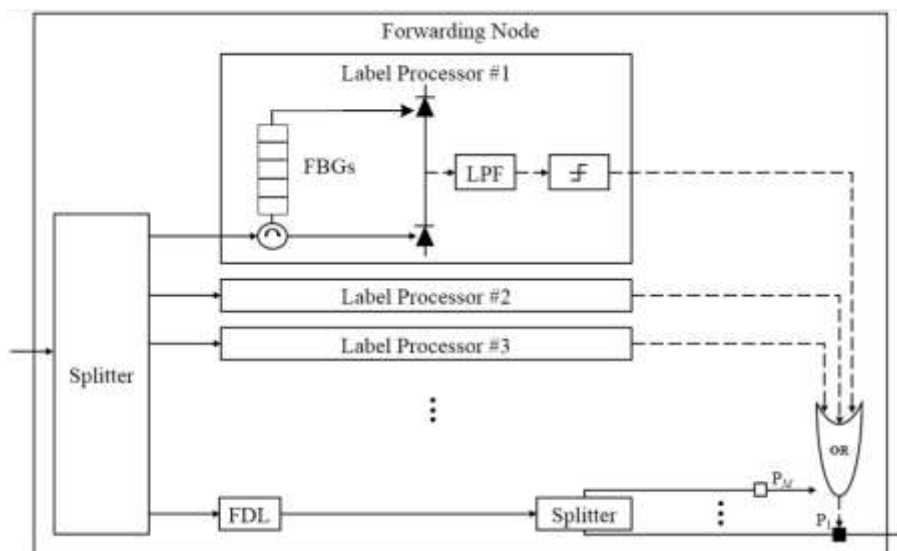

Figure 2: Configuration of Packet Switcher with Multi-Rate Detection at Forwarding Node

3. NUMERICAL RESULTS AND DISSCUSSIONS

For packet switched in MPLS network, the number of stacked labels is limited by successful decoding the desired label from interferences of other labels in the same optical band. In numerical analysis, we assume that the light source has flat power spectrum density (PSD) in coded bandwidth. Under this condition, the main restrictions on label detecting are thermal noise and PIIN [4]. Assume that each un-polarized broadband light source (BLS) has bandwidth ν , and magnitude P/ν , where P is the received BLS power at the label decoder. The variance of thermal noise σ_t^2 can be expressed as

$$\sigma_t^2 = 4K_b T_n B / R_L, \quad (1)$$

where K_b is Boltzmann's constant, T_n is the absolute receiver noise temperature, B is the electrical bandwidth, and R_L is the receiver load resistor. The variance of PIIN σ_p^2 can be written as the following expression.

$$\sigma_p^2 = \frac{P^2 R^2 B}{N\nu} \left[\omega + \frac{3\omega - 2\lambda}{\omega - \lambda} \lambda (K - 1) + \frac{\omega^2 \lambda}{(\omega - \lambda) N} (K - 1)(K - 2) \right] \quad (2)$$

where ω , λ , and N is the weight, cross-correlation and length of label code, respectively. R is the responsivity of photo-diode and K is the number of stacked labels. Then, the photo-current I shown at the decoder output is written as

$$I = RPw / N \quad (3)$$

Finally, we can obtain signal-to-noise ratio (SNR) of the decoded label signals from Eq. (1) - (3).

$$\text{SNR} = \frac{I^2}{\sigma_t^2 + \sigma_p^2} \quad (4)$$

Using Gaussian approximation, BER for type#1 packet is expressed as

$$\text{BER}_{(\text{type}\#1)} = \frac{1}{2} \text{erfc} \left(\sqrt{\frac{\text{SNR}}{4}} \right) \quad (5)$$

The type#2 packet has to interlace the payload bits of two split packets, so the error rate of this packet is written as

$$\text{BER}_{(\text{type}\#2)} = 1 - (1 - \text{BER}_{(\text{type}\#1)}^2) \approx 2\text{BER}_{(\text{type}\#1)} \quad (6)$$

The relation between the number of stacked labels and BERs for two types of packets is shown in Fig. 3. The parameters used in the simulations are listed in Table 1. The performances of two packets are almost the same. BER increases with the stacked label number. This is due to the increase in PIIN, which results from the square-law operation of photo-diode when an optical signal is down-converting to an electrical carrier. In this simulation, SQC codes of ($N=13$, $\omega=4$, $\lambda=1$) and (31,6,1), as well as M-sequence codes of (31,16,8) are applied to construct SAC labels. As shown in Eq. (2), the key factor to suppress PIIN effect is in-phase cross-correlation λ . This is the reason that packets with SQC labels have better BERs than those of M-sequence labels. Furthermore, when the label with long code length is used, the number of stacked labels is increased, and better performance is reached. However, more FBGs are required for encoding or decoding long-length SAC labels, which increases system complexity at label encoders. The tradeoff between node simplicity and switching performance should be taken account when such network is designed.

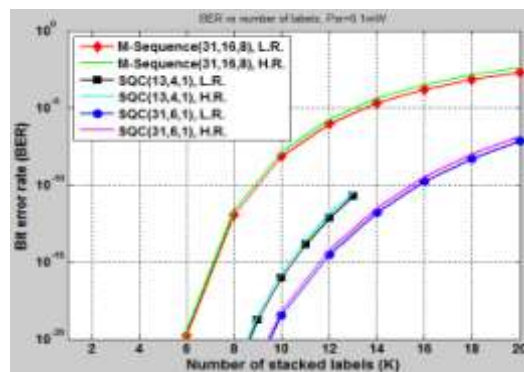

Figure 3: BER versus Stacked Label Number

Table 1: Parameters used in the Simulation

Parameter Name	Value
Electrical bandwidth	$B = 200\text{MHz}$
BLS bandwidth	$\nu = 1.4\text{THz}$
BLS power	$P = 0.1\text{mW}$
Temperature at receiver	$T_n = 300\text{K}$
Receiver load resistor	$R_L = 1030\Omega$
Responsivity	$R = 0.75\text{A/W}$

4. CONSLUSIONS

In this paper, a system configuration of multi-rate MPLS network based on SAC labels is proposed. The network performance is investigated by deriving BER values. Simulation results show that similar BERs are measured for packets with different bit-rates, which implies that the proposed system is enabled to support multi-rate transmissions. Moreover, impacts of label lengths and types on system BER are also discussed.

5. REFERENCES

- [1] J. S. Choi, “Design and Implementation of a Stateful PCE-Based Unified Control and Management Framework for Carrier-Grade MPLS-TP Networks,” *J. Lightw. Technol.*, vol. 34, no. 3, pp. 836-844, 2016.
- [2] S. V. Maric and K. N. Lau, “Multirate Fiber-Optic CDMA: System Design and Performance Analysis,” *J. Lightw. Technol.*, vol. 16, no. 1, pp. 9-17, 1998.
- [3] A. E. Farghal, H. M. H. Shalaby, and Z. Kawasaki, “Multirate Multiservice All-Optical Code Switched GMPLS Core Network Utilizing Multicode Variable-Weight Optical Code-Division Multiplexing,” *J. Opt. Commun. Netw.*, vol. 6, no. 8, pp. 670–683, 2014.
- [4] K. S. Chen, C. C. Yang and J. F. Huang, “Using Stuffed Quadratic Congruence Codes for SAC Labels in Optical Packet Switching Network,” *IEEE Commun. Lett.*, vol. 19, no. 7, pp. 1093-1096, 2015.
- [5] P. Seddighian, S. Ayotte, J. B. Rosas-Fernandez, J. Penon, L. A. Rusch and S. LaRochelle, “Label Stacking in Photonic Packet-Switched Networks with Spectral Amplitude Code Labels,” *J. Lightw. Technol.*, vol. 25, no. 2, pp. 463-471, 2007.
- [6] Z. Wei, H.M.H. Shalaby, and H. Ghafouri-Shiraz, “Modified Quadratic Congruence Codes for Fiber Bragg Grating-Based Spectral-Amplitude-Coding Optical CDMA Systems,” *J. Lightw. Technol.*, vol. 19, pp. 1274–1281, 2001.